

DATA SHEET

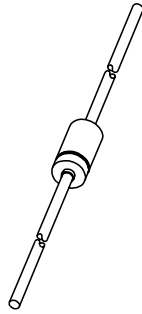

KTY84 series **Silicon temperature sensors**

Product specification
Supersedes data of 2000 Aug 25

2003 Sep 15

Silicon temperature sensors

KTY84 series

DESCRIPTION

The temperature sensors in the KTY84-1 series have a positive temperature coefficient of resistance and are suitable for use in measurement and control systems over a temperature range of -40 to +300 °C. The sensors are encapsulated in the SOD68 (DO-34) package. The leads are nickel plated.

Tolerances of 0.5% or other special selections are available on request.

MARKING

TYPE NUMBER	MARKING CODE
KTY84/130	KT84L
KTY84/150	KT84M
KTY84/151	KT84O

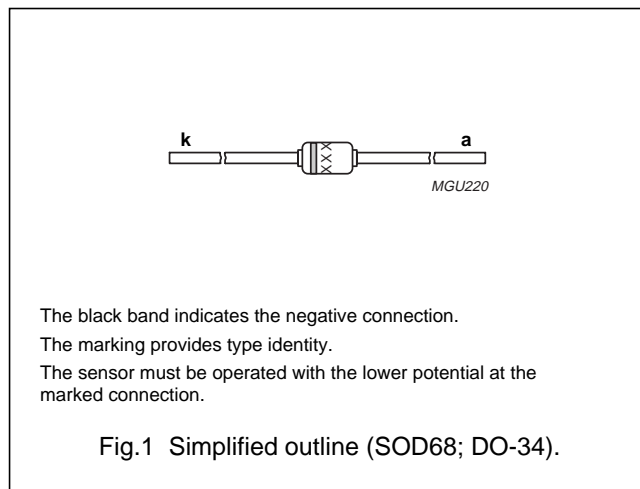

QUICK REFERENCE DATA

SYMBOL	PARAMETER	CONDITIONS	MIN.	MAX.	UNIT
R ₁₀₀	sensor resistance	T _{amb} = 100 °C; I _{cont} = 2 mA			
	KTY84/130		970	1030	Ω
	KTY84/150		950	1050	Ω
	KTY84/151		950	1000	Ω
T _{amb}	ambient operating temperature		-40	+300	°C

LIMITING VALUES

In accordance with the Absolute Maximum Rating System (IEC 60134).

SYMBOL	PARAMETER	CONDITIONS	MIN.	MAX.	UNIT
I _{cont}	continuous sensor current	in free air; T _{amb} = 25 °C; note 1	-	10	mA
		in free air; T _{amb} = 300 °C	-	2	mA
T _{amb}	ambient operating temperature		-40	+300	°C
T _{stg}	storage temperature		-55	+300	°C

Note

- For temperatures greater than 200 °C, a sensor current of I_{cont} = 2 mA must be used.

Silicon temperature sensors

KTY84 series

CHARACTERISTICS

$T_{amb} = 100\text{ }^{\circ}\text{C}$ in liquid, unless otherwise specified.

SYMBOL	PARAMETER	CONDITIONS	MIN.	TYP.	MAX.	UNIT
R_{100}	sensor resistance	$I_{cont} = 2\text{ mA}$				
	KTY84/130		970	–	1030	Ω
	KTY84/150		950	–	1050	Ω
	KTY84/151		950	–	1000	Ω
TC	temperature coefficient		–	0.61	–	%/K
R_{250}/R_{100}	resistance ratio	$T_{amb} = 250\text{ }^{\circ}\text{C}$ and $100\text{ }^{\circ}\text{C}$	2.111	2.166	2.221	
R_{25}/R_{100}	resistance ratio	$T_{amb} = 25\text{ }^{\circ}\text{C}$ and $100\text{ }^{\circ}\text{C}$	0.595	0.603	0.611	
τ	thermal time constant; note 1	in still air	–	20	–	s
		in still liquid; note 2	–	1	–	s
		in flowing liquid; note 2	–	0.5	–	s
	rated temperature range		–40	–	+300	$^{\circ}\text{C}$

Notes

1. The thermal time constant is the time taken for the sensor to reach 63.2% of the total temperature difference. For example, if a sensor with a temperature of $25\text{ }^{\circ}\text{C}$ is moved to an environment with an ambient temperature of $100\text{ }^{\circ}\text{C}$, the time for the sensor to reach a temperature of $72.4\text{ }^{\circ}\text{C}$ is the thermal time constant.
2. Inert liquid, e.g. FC43 manufactured by the 3M company.

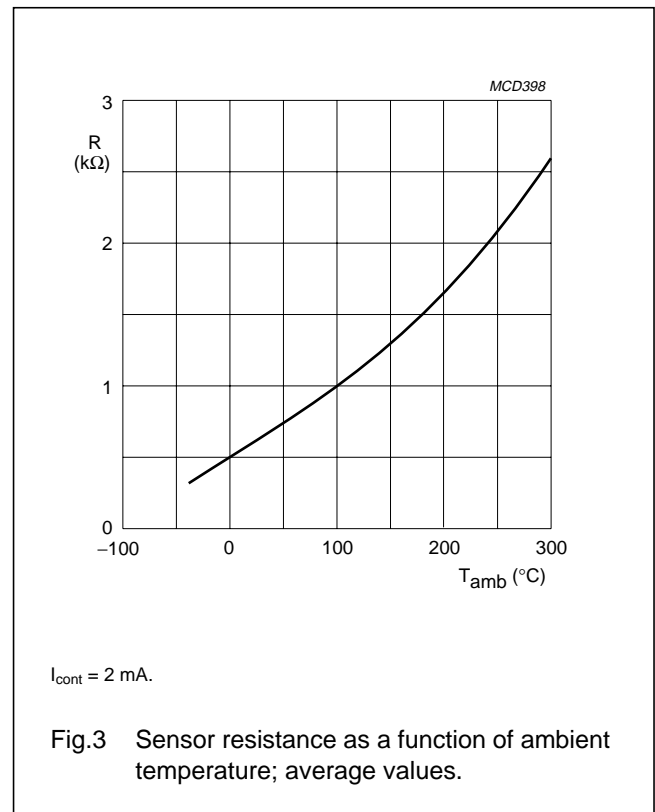
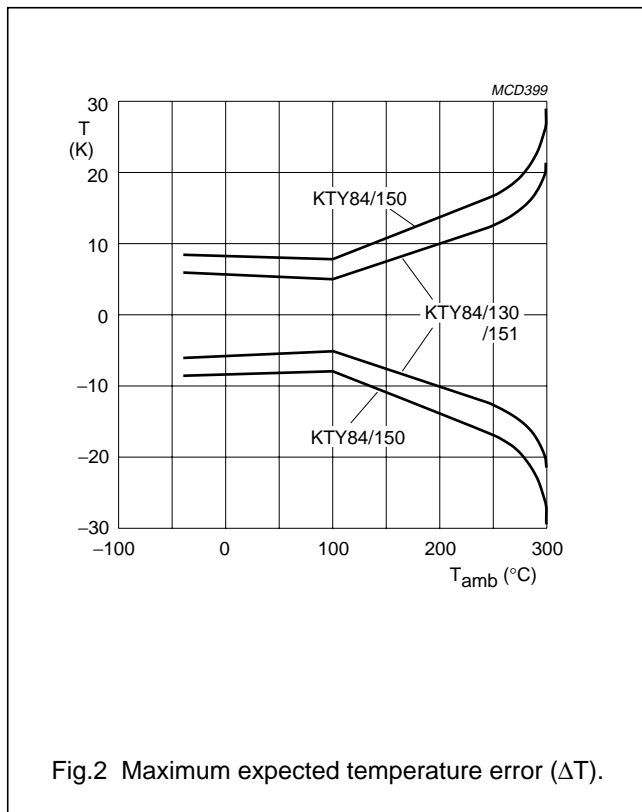

Silicon temperature sensors

KTY84 series

Table 1 Ambient temperature, corresponding resistance, temperature coefficient and maximum expected temperature error for KTY84/130 and KTY84/150 $I_{\text{cont}} = 2 \text{ mA}$.

AMBIENT TEMPERATURE		TEMP. COEFF. (%/K)	KTY84/130				KTY84/150				
(°C)	(°F)		RESISTANCE (Ω)			TEMP. ERROR (K)	RESISTANCE (Ω)			TEMP. ERROR (K)	
			MIN.	TYP.	MAX.		MIN.	TYP.	MAX.		
-40	-40	0.84	340	359	379	±6.48	332	359	386	±8.85	
-30	-22	0.83	370	391	411	±6.36	362	391	419	±8.76	
-20	-4	0.82	403	424	446	±6.26	394	424	455	±8.7	
-10	14	0.80	437	460	483	±6.16	428	460	492	±8.65	
0	32	0.79	474	498	522	±6.07	464	498	532	±8.61	
10	50	0.77	514	538	563	±5.98	503	538	574	±8.58	
20	68	0.75	555	581	607	±5.89	544	581	618	±8.55	
25	77	0.74	577	603	629	±5.84	565	603	641	±8.54	
30	86	0.73	599	626	652	±5.79	587	626	665	±8.53	
40	104	0.71	645	672	700	±5.69	632	672	713	±8.5	
50	122	0.70	694	722	750	±5.59	679	722	764	±8.46	
60	140	0.68	744	773	801	±5.47	729	773	817	±8.42	
70	158	0.66	797	826	855	±5.34	781	826	872	±8.37	
80	176	0.64	852	882	912	±5.21	835	882	929	±8.31	
90	194	0.63	910	940	970	±5.06	891	940	989	±8.25	
100	212	0.61	970	1000	1030	±4.9	950	1000	1050	±8.17	
110	230	0.60	1029	1062	1096	±5.31	1007	1062	1117	±8.66	
120	248	0.58	1089	1127	1164	±5.73	1067	1127	1187	±9.17	
130	266	0.57	1152	1194	1235	±6.17	1128	1194	1259	±9.69	
140	284	0.55	1216	1262	1309	±6.63	1191	1262	1334	±10.24	
150	302	0.54	1282	1334	1385	±7.1	1256	1334	1412	±10.8	
160	320	0.53	1350	1407	1463	±7.59	1322	1407	1492	±11.37	
170	338	0.52	1420	1482	1544	±8.1	1391	1482	1574	±11.96	
180	356	0.51	1492	1560	1628	±8.62	1461	1560	1659	±12.58	
190	374	0.49	1566	1640	1714	±9.15	1533	1640	1747	±13.2	
200	392	0.48	1641	1722	1803	±9.71	1607	1722	1837	±13.85	
210	410	0.47	1719	1807	1894	±10.28	1683	1807	1931	±14.51	
220	428	0.46	1798	1893	1988	±10.87	1760	1893	2026	±15.19	
230	446	0.45	1879	1982	2085	±11.47	1839	1982	2125	±15.88	
240	464	0.44	1962	2073	2184	±12.09	1920	2073	2226	±16.59	
250	482	0.44	2046	2166	2286	±12.73	2003	2166	2329	±17.32	
260	500	0.42	2132	2261	2390	±13.44	2087	2261	2436	±18.15	
270	518	0.41	2219	2357	2496	±14.44	2172	2357	2543	±19.36	
280	536	0.38	2304	2452	2600	±15.94	2255	2452	2650	±21.21	
290	554	0.34	2384	2542	2700	±18.26	2333	2542	2751	±24.14	
300	572	0.29	2456	2624	2791	±22.12	2404	2624	2844	±29.05	

Silicon temperature sensors

KTY84 series

Table 2 Ambient temperature, corresponding resistance, temperature coefficient and maximum expected temperature error for KTY84/151 $I_{\text{cont}} = 2 \text{ mA}$.

AMBIENT TEMPERATURE		TEMP. COEFF. (%/K)	KTY84/151			
(°C)	(°F)		RESISTANCE (Ω)			TEMP. ERROR (K)
		MIN.	TYP.	MAX.		
-40	-40	0.84	332	350	368	± 5.97
-30	-22	0.83	362	381	399	± 5.84
-20	-4	0.82	394	414	433	± 5.72
-10	14	0.80	428	449	469	± 5.62
0	32	0.79	464	486	507	± 5.51
10	50	0.77	503	525	547	± 5.41
20	68	0.75	544	566	589	± 5.31
25	77	0.74	565	588	611	± 5.25
30	86	0.73	587	610	633	± 5.2
40	104	0.71	632	656	679	± 5.08
50	122	0.70	679	704	728	± 4.96
60	140	0.68	729	754	778	± 4.83
70	158	0.66	781	806	831	± 4.68
80	176	0.64	835	860	885	± 4.53
90	194	0.63	891	916	942	± 4.37
100	212	0.61	950	975	1000	± 4.19
110	230	0.60	1007	1036	1064	± 4.58
120	248	0.58	1067	1099	1131	± 4.99
130	266	0.57	1128	1164	1199	± 5.41
140	284	0.55	1191	1231	1271	± 5.84
150	302	0.54	1256	1300	1345	± 6.3
160	320	0.53	1322	1372	1421	± 6.77
170	338	0.52	1391	1445	1500	± 7.25
180	356	0.51	1461	1521	1581	± 7.75
190	374	0.49	1533	1599	1664	± 8.27
200	392	0.48	1607	1679	1751	± 8.81
210	410	0.47	1683	1761	1839	± 9.36
220	428	0.46	1760	1846	1931	± 9.93
230	446	0.45	1839	1932	2024	± 10.51
240	464	0.44	1920	2021	2121	± 11.11
250	482	0.44	2003	2112	2220	± 11.73
260	500	0.42	2087	2205	2321	± 12.42
270	518	0.41	2172	2298	2424	± 13.37
280	536	0.38	2257	2391	2525	± 14.79
290	554	0.34	2335	2479	2622	± 16.98
300	572	0.29	2406	2558	2710	± 20.61

Silicon temperature sensors

KTY84 series

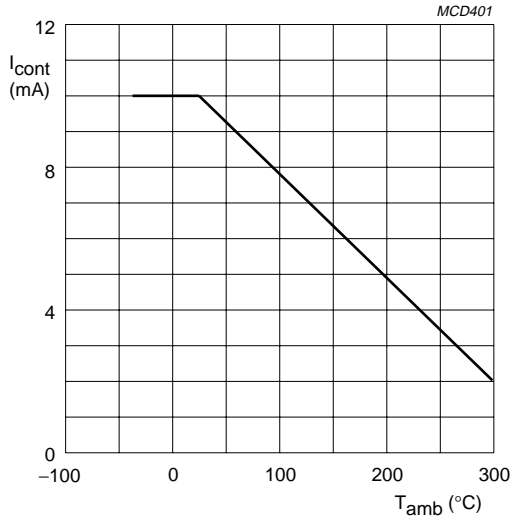
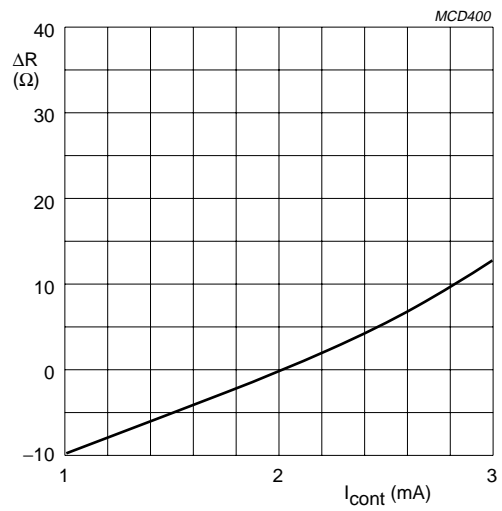

Fig.4 Maximum operating current for safe operation.



$T_{amb} = 100$ °C.

Fig.5 Deviation of sensor resistance as a function of operating current in still liquid.

Silicon temperature sensors

KTY84 series

PACKAGE OUTLINE

Hermetically sealed glass package; axial leaded; 2 leads

SOD68

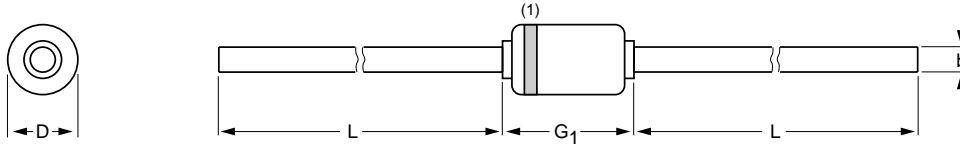

DIMENSIONS (mm are the original dimensions)

UNIT	b max.	D max.	G ₁ max.	L min.
mm	0.55	1.6	3.04	25.4

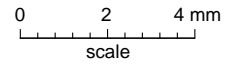

Note

1. The marking band indicates the cathode.

OUTLINE VERSION	REFERENCES				EUROPEAN PROJECTION	ISSUE DATE
	IEC	JEDEC	EIAJ			
SOD68		DO-34				97-06-09

Silicon temperature sensors

KTY84 series

DATA SHEET STATUS

LEVEL	DATA SHEET STATUS ⁽¹⁾	PRODUCT STATUS ⁽²⁾⁽³⁾	DEFINITION
I	Objective data	Development	This data sheet contains data from the objective specification for product development. Philips Semiconductors reserves the right to change the specification in any manner without notice.
II	Preliminary data	Qualification	This data sheet contains data from the preliminary specification. Supplementary data will be published at a later date. Philips Semiconductors reserves the right to change the specification without notice, in order to improve the design and supply the best possible product.
III	Product data	Production	This data sheet contains data from the product specification. Philips Semiconductors reserves the right to make changes at any time in order to improve the design, manufacturing and supply. Relevant changes will be communicated via a Customer Product/Process Change Notification (CPCN).

Notes

1. Please consult the most recently issued data sheet before initiating or completing a design.
2. The product status of the device(s) described in this data sheet may have changed since this data sheet was published. The latest information is available on the Internet at URL <http://www.semiconductors.philips.com>.
3. For data sheets describing multiple type numbers, the highest-level product status determines the data sheet status.

DEFINITIONS

Short-form specification — The data in a short-form specification is extracted from a full data sheet with the same type number and title. For detailed information see the relevant data sheet or data handbook.

Limiting values definition — Limiting values given are in accordance with the Absolute Maximum Rating System (IEC 60134). Stress above one or more of the limiting values may cause permanent damage to the device. These are stress ratings only and operation of the device at these or at any other conditions above those given in the Characteristics sections of the specification is not implied. Exposure to limiting values for extended periods may affect device reliability.

Application information — Applications that are described herein for any of these products are for illustrative purposes only. Philips Semiconductors make no representation or warranty that such applications will be suitable for the specified use without further testing or modification.

DISCLAIMERS

Life support applications — These products are not designed for use in life support appliances, devices, or systems where malfunction of these products can reasonably be expected to result in personal injury. Philips Semiconductors customers using or selling these products for use in such applications do so at their own risk and agree to fully indemnify Philips Semiconductors for any damages resulting from such application.

Right to make changes — Philips Semiconductors reserves the right to make changes in the products - including circuits, standard cells, and/or software - described or contained herein in order to improve design and/or performance. When the product is in full production (status 'Production'), relevant changes will be communicated via a Customer Product/Process Change Notification (CPCN). Philips Semiconductors assumes no responsibility or liability for the use of any of these products, conveys no licence or title under any patent, copyright, or mask work right to these products, and makes no representations or warranties that these products are free from patent, copyright, or mask work right infringement, unless otherwise specified.

Philips Semiconductors – a worldwide company

Contact information

For additional information please visit <http://www.semiconductors.philips.com>. Fax: +31 40 27 24825

For sales offices addresses send e-mail to: sales.addresses@www.semiconductors.philips.com.

© Koninklijke Philips Electronics N.V. 2003

SCA75

All rights are reserved. Reproduction in whole or in part is prohibited without the prior written consent of the copyright owner.

The information presented in this document does not form part of any quotation or contract, is believed to be accurate and reliable and may be changed without notice. No liability will be accepted by the publisher for any consequence of its use. Publication thereof does not convey nor imply any license under patent- or other industrial or intellectual property rights.

Printed in The Netherlands

R75/05/pp9

Date of release: 2003 Sep 15

Document order number: 9397 750 11749

Let's make things better.

**Philips
Semiconductors**



PHILIPS